



The NESTechnology™ Hotsy Pump

#1 in North America for
High-Pressure Cleaning Equipment

The Hotsy Pump Engineered for durability and performance. Providing 3 times longer seal life.



Nesting Assembly Cross Section View:

"U" Seal Assembly (Shown Installed)

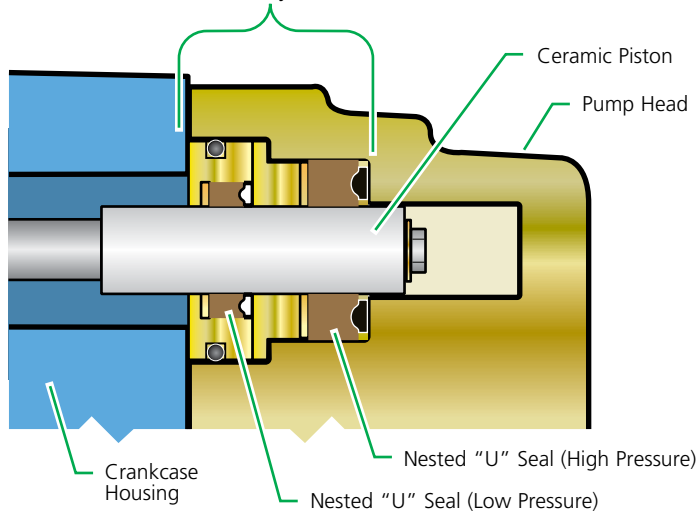

Cutaway View of U vs V:

The sealing contact surface is twice
as large with the U-Seals

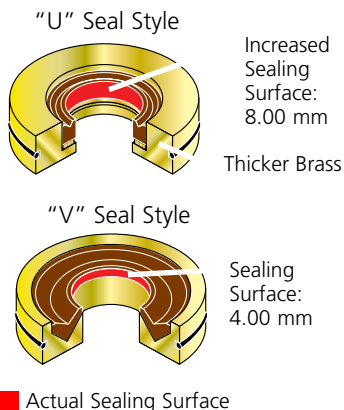

Side by Side Comparison

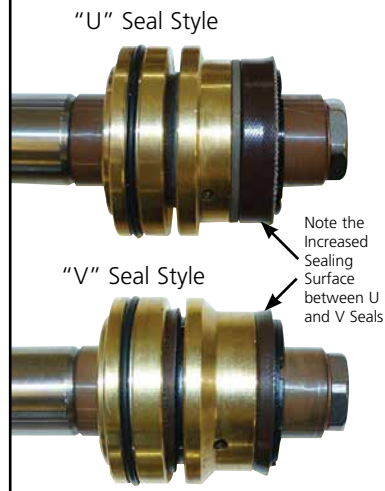

Hotsy Pumps featuring NESTechnology™

Hotsy has introduced the latest innovation to the Hotsy pump - NESTechnology™.

What is NESTechnology™? It stands for Nested Seal Technology, where the pump actually "nests" the seals of the pump's high-pressure packing assembly in place, supporting the side walls, and resulting in greatly increased seal life.

The unique technology of the nesting assembly includes new high and low-pressure U-shaped seals surrounded by thicker brass pressure rings. This provides better wall support while withstanding higher water temperatures. This results in Hotsy pumps having **3 times the seal life** over similar pumps in the industry.

- Extended time between seal replacement, greatly reducing maintenance costs.
- Teflon bronze rings support the U-Seal to prevent premature wear and loss of pressure.
- The low-pressure U-Seal has a unique double lip to provide for greater suction and less chance of water leakage.
- Increased wall thickness of the brass pressure rings resist cracking and provide a solid foundation for the seals.
- The nesting assembly is stronger and holds up better to spikes in water pressure, which occur every time the gun is triggered.
- Existing Hotsy pumps can be upgraded to utilize NESTechnology's unique nesting assembly. All parts are interchangeable, and fit within the brass manifold.
- Seals are rated for temperatures up to 185°F.

Seals are a wear item in a pump because of the intense pressure they are subjected to. Hotsy's nested seal technology holds up better, and has improved the seal life by changing the geometry of the packing assembly and providing greater support to the seals. The end result is a high-performance pump with extended service life.

The Hotsy Pump's rugged design features many benefits:

- Four frame sizes: one duplex, and three triplex sizes - small, medium, large
- Externally accessible check valves
- Two inlet and discharge ports facilitate system installation
- Anodized aluminum crankcase
- Polished ceramic plungers reduce seal wear
- Oversized crankshaft and connecting rods
- Heavy-duty roller bearings or heavy-duty tapered roller bearings
- Internally-ported, self-lubricating seals
- Pumps available for pulley, direct or gear-reducer drive
- 7-year warranty on the oil-end of the pump

The Hotsy Pump Legacy

Central to every Hotsy pressure washer lies the heart of the machine, the Hotsy high-pressure pump. The Hotsy pump is highly efficient with a history of engineering excellence.

Hotsy has been manufacturing our own pumps since 1984. Over the years, design changes have been implemented to improve the efficiency of the pumps, making the Hotsy pump one of the most efficient and durable pumps on the market.

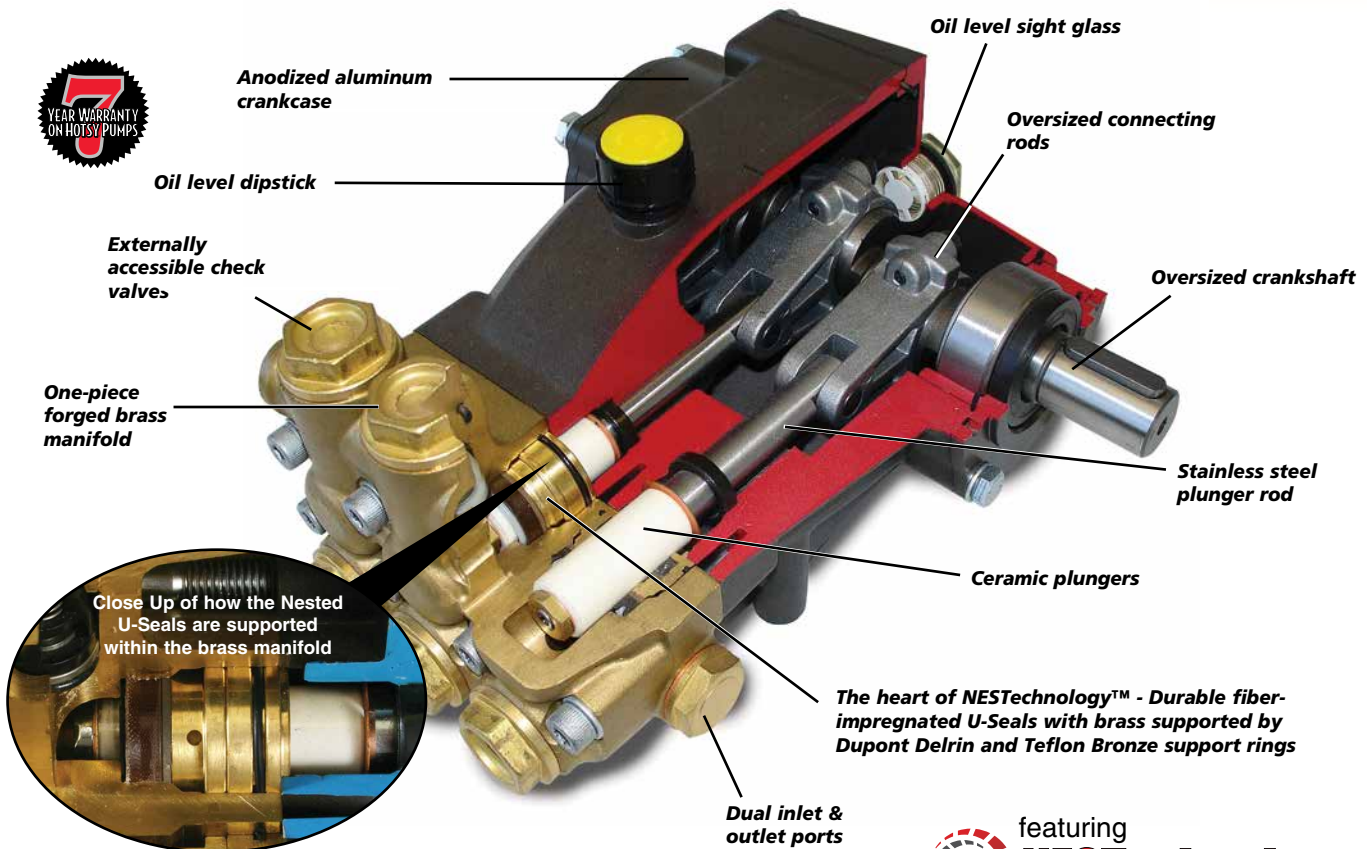

Distributed by:

hotsy *Nothing Cleans Like a Hotsy!*

Tel: (800) 525-1976 Fax: (888) 880-9631
www.Hotsy.com email: info@Hotsy.com
P/N 9.800-985.0 Effective 9/15 Specifications & product descriptions subject to change without notice. ©2015 Karcher North America

NOTE: We are constantly improving and updating our products. Consequently, pictures, features & specifications in this brochure may differ slightly from current models. Flow rates & pressure ratings may vary due to variances allowed by manufacturers of our machine components. We attempt to keep our machine performance within $\pm 5\%$ of listed specifications.