

345

LUX: 800 @ 50 cm
LUMEN: 430
LIGHTING ANGLE: 120°

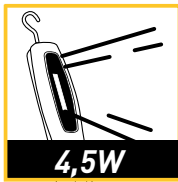

Next Generation
50% MORE LIGHT

SOFT TOUCH HANDLE

PROTECTED SWITCH



NEW LITHIUM BATTERY

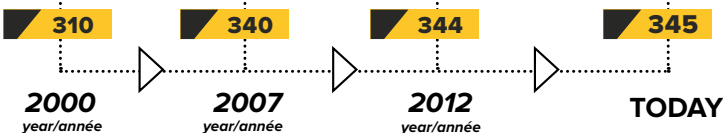

Never ending evolution leading to perfection

EN Technical Features

- COB LED source
- Electronic control of the charge: the lamp can be kept always on the battery charger
- Shock resistant and reliable
- **Pilot light on the lamp:**
- **Fixed red:** battery flat.
- **Flashing red:** lamp in recharge.
- **Fixed green:** the charge is completed. Charge maintenance function.

Caution: When the battery is almost down, the pilot led on the lamp is red. When the switch doesn't stay inserted anymore, the battery is flat. Recharge the lamp.

DE Technische Merkmale

- Lichtquelle: COB LED
 - Elektronische Kontrolle der Aufladung: die Lampe kann immer im Ladegerät bleiben
 - Stoßfest und zuverlässig
 - **Kontrollleuchte auf der Lampe:**
 - **Rote Dauerleuchte:** leerer Akku
 - **Rote Blinkleuchte:** die Lampe ist in Wiederaufladung
 - **Grüne Dauerleuchte:** Laden fertiggestellt. Ladeerhaltung funktion.
- Achtung:** Wenn die Batterie fast leer ist, leuchtet das rote Kontrollled in der Lampe auf. Wenn der Schalter nicht mehr eingeschaltet ist, bedeutet es, dass die batterie vollständig leer ist. Die Lampe wieder laden.

FR Caracteristiques Techniques

- Source de lumière COB LED
 - Contrôle électronique de la charge: la lampe peut être toujours laissée sur le chargeur
 - Résistant aux chocs et fiable
 - **Voyant lumineux sur la lampe:**
 - **Rouge fixe:** batterie vide
 - **Rouge clignotant:** lampe en recharge
 - **Vert fixe:** recharge terminée. Fonction maintien de charge
- Attention:** Quand la batterie est presque à plat, le voyant sur la lampe est rouge. Lorsque l'interrupteur ne reste plus enclenché, cela signifie que la batterie est à plat. Recharger la lampe.

ES Características Técnicas

- Fuente del luz: COB SMD
 - Control electrónico de la carga: la lámpara puede dejarse siempre en el cargador
 - Resistente a los golpes y fiable
 - **Indicador luminoso sobre la lámpara:**
 - **Rojo fijo:** batería vacía;
 - **Rojo parpadeante:** lámpara en recarga;
 - **Verde fijo:** carga ultimada. Función mantenimiento de carga.
- Atencion:** Cuando la batería está casi descargada, se encendera l'indicador rojo en la lámpara. Cuando el interruptor no funciona al pulsarlo, significa que la batería está completamente descargada. Recargue la lámpara.

ART.	345
Description	Rechargeable COB lamp with charger
Light Source	COB LED
Battery	3,7 V LiPo - 4400 mAh
Battery Charger	100/240 V (50/60 Hz) - Output 5V 2A
	340x160x90 mm - 0,900 Kg

ART. 345/12

Displayer with 12 lamps
Presentoir avec 12 lampes
Ständer mit 12 Lampen
Expositor con 12 lamparas.

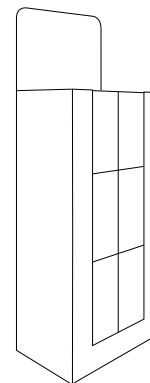

Dimensions

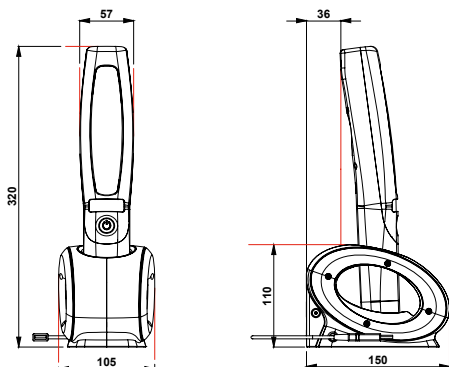

Spare Parts

- ART. 345/VY** - Transparent cover
- ART. 345/L** - Lamp
- ART. 345/C** - Charging base

