

2-polig

1-polig

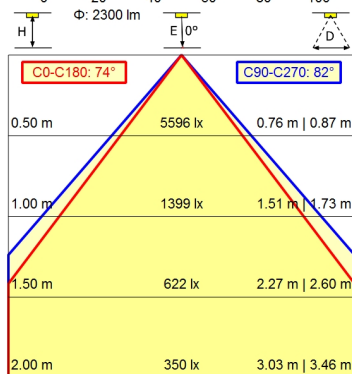
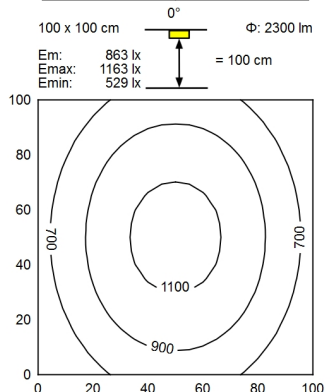
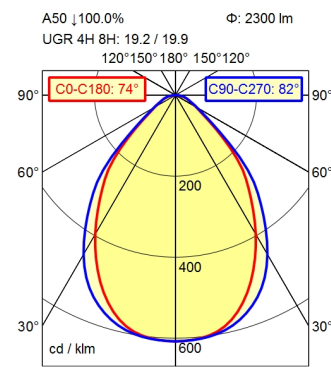

light source
work equipment
connected load
power consumption
luminous flux
luminous efficiency
light type/-color
colour temperatur
color rendering index
light distribution
direct ratio
beam angle
chromaticity tolerance LED
glare control
luminance (L65)
unified glare rating (4H 8H)
system of protection
class of protection
technology
operation
housing
cover
dimming Range
weight (net)
mains lead
fastening
decorative contrast side parts

LED
electronic ballast
220-240V, 50/60Hz
env. 26 W
approx. 2.300 lm
approx. 88 lm/W
cold white
approx. 4.000 K
CRI > 90; R9 > 50
direct
approx. 100 %
75%
< 3 SDCM
conical prismatic screen
<= 3800 cd/m²
<= 22
IP 20
I
continuously dimmable; DALI; Touch DIM
rocker switch
aluminium/plastic; anodised; aluminium coloured
anodised
structured; plastic
1-100%
ca. 4,3 kg
ca. 0,08 m; connector; 2-polig; 1-polig
extension range of rise-and-fall pendant 0.3 - 1.3 m
black

Workplace-system luminaire Tameto SAHZQ 66 R

112984000-00551377

