

CEE 7/VII

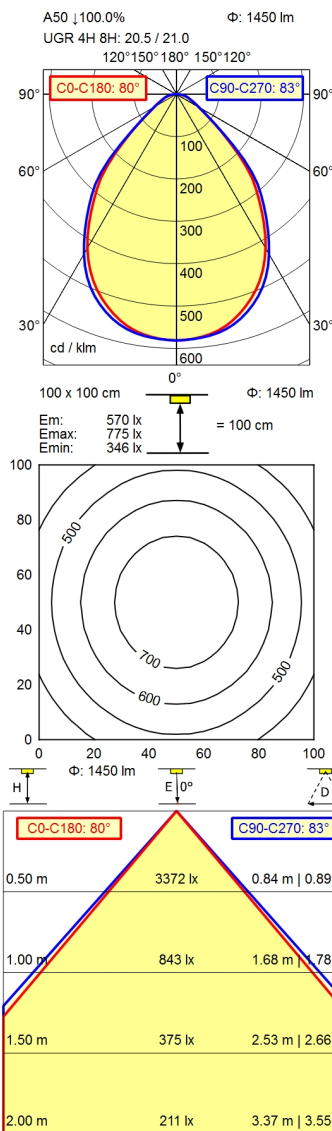

light source
work equipment
connected load
power consumption
luminous flux
luminous efficiency
light type/-color
colour temperatur
color rendering index
light distribution
direct ratio
beam angle
chromaticity tolerance LED
glare control
luminance (L65)
unified glare rating (4H 8H)
system of protection
class of protection
technology
operation
housing
cover
dimming Range
weight (net)
mains lead
design
fastening
decorative contrast side parts

LED
electronic ballast dimable digital
220-240V, 50/60Hz
env. 23 W
approx. 1.450 lm
approx. 63 lm/W
adjustable white
approx. 3.000 - 6.500 K
CRI > 90; R9 > 50
direct; symmetric
approx. 100 %
80°
< 3 SDCM
conical prismatic screen
<= 5200 cd/m²
<= 22
IP 20
I
continuously dimmable; radio-controlled; no notice
external
aluminium/plastic; anodised; aluminium coloured
anodised
structured
0,1-100%
ca. 2,4 kg
ca. 3,00 m; mains plug; CEE 7/VII
mounted version
screw down lash
black

Workplace-system luminaire Tameto SAHKQ 60 RC

114259000-00805715

