

Midi / LED/Flash/EVS/Multi-t. sounder 431  
**LED Siren BM 32 tne 115-230VAC YE**



Part No.: 431.300.60



MECHANICAL DATA	
Height	171 mm
Diameter	146 mm
Materials	PC PC/ABS
Dome colour	Yellow
Housing colour	Black
Protection category	IP65
Connection	Screw terminals
cross-sectional area maximum	1,50mm <sup>2</sup> / 16AWG
Cable entry	Membrane grommet
Cable entry minimum	d = 1 mm
Cable entry maximum	d = 13 mm
Tension relief	Present (conforms to VDI)
Type of fixing	Base mounting
Working temperature minimum	-30°C
Working temperature maximum	+50°C
UL Type Rating	Type 12
Weight with packaging	645 g
Product weight	502 g

ELECTRICAL DATA	
Operating voltage	115-230V
Operating voltage type	AC
Operating voltage frequency	50Hz at 230V 60Hz at 115V
Operating voltage tolerance	+/- 10%
Rated operational voltage	230 VAC
Rated operational current	155 mA
Rated inrush current	400 mA
Protection class	Protection class 2
Pollution degree	3
Overvoltage category	II
Isolation voltage	Ui = 250V; Uimp = 2.500V

OPTICAL DATA	
Light source	LED
Light colour	Yellow
Optical signal image	EVS Flash Permanent

! For additional installation and mounting information, refer to the appropriate user guide at [www.werma.com](http://www.werma.com). This printed copy is for information only and is subject to alteration.

Midi / LED/Flash/EVS/Multi-t. sounder 431

**LED Siren BM 32 tne 115-230VAC YE**

Service life optical	50,000 h maximum
----------------------	------------------

ACUSTICAL DATA	
Volume/dB(max) at 1m distance	108,0 dB (A)
Acoustic signal image	Multi-tone
Number of tones	32 tone
Acoustic service life	5,000 h minimum

**DRAWING**

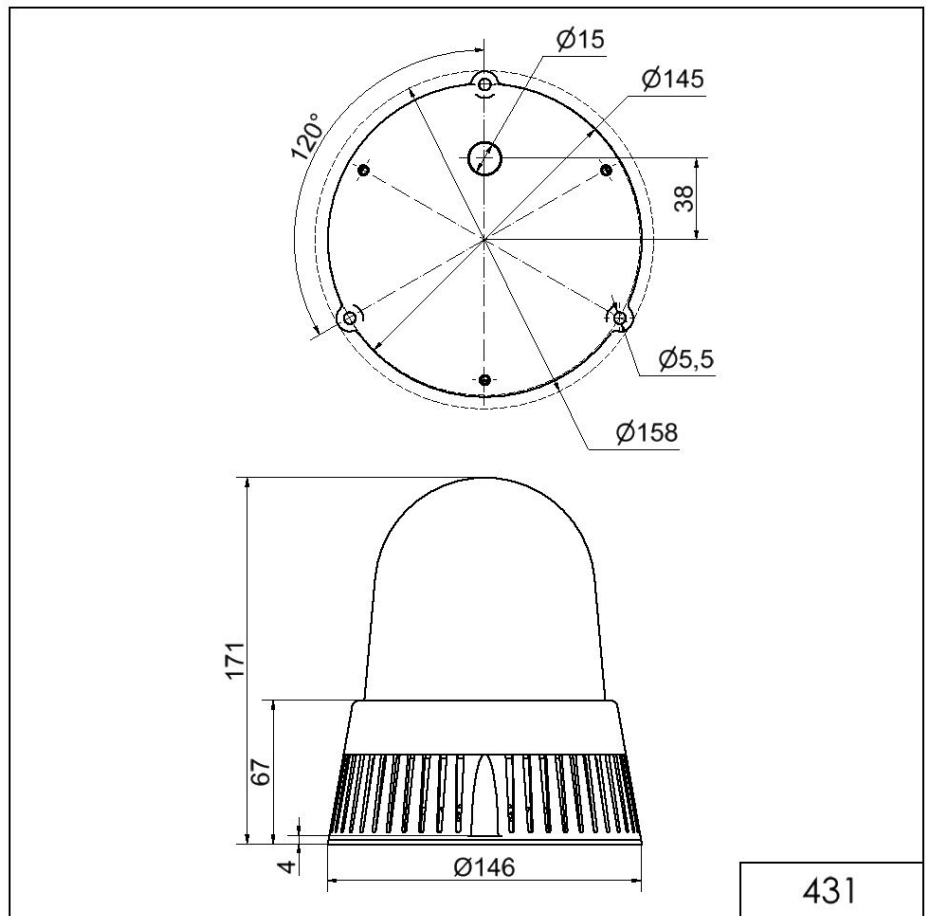

! For additional installation and mounting information, refer to the appropriate user guide at [www.werma.com](http://www.werma.com). This printed copy is for information only and is subject to alteration.